

APPLICATION

MGM Model 143 Back Pressure Check Valves are designed to allow flow in one direction only. The check mechanism is held in the closed position by a spring, which stops flow in the reverse direction. When pressure from flow in the permitted direction overcomes the force of the spring, the check mechanism opens. When flow stops or reverses, the check closes. The metal-to-metal seating allows slight leakage after closure. The valves are recommended for use in inflowing lines.

Model 143 Back Pressure Check Valves are designed for installation in lines that flow into pressure tanks where threaded connections are required. These valves should be used in inflowing lines when outward flow is never required. Model 143 Back Pressure Check Valves are machined from solid bar stock with one weld in the body.

Model 143 Back Pressure Check Valves can be mounted in any orientation. Each valve will have the proper flow direction indicated by an arrow stenciled into the body. As with all MGM Back Pressure Check Valves, do not reduce outlet pipe size. Back Pressure Check Valves should be installed as close as possible to the container, with the poppet stem pointed inwardly toward the container.

FEATURES

- Designed with male and female NPT threaded connections on each end.
- Available in ½” to 3” NPT threads.
- Generous flow channels provide minimal pressure drops.
- Heavy duty steel construction will withstand temperatures from -40° F (-40° C) to +300° F (+148° C) and internal pressures up to 3000 psig (207 barg).
- Complete stainless steel construction available for greater range of operating temperatures.

STANDARD MATERIALS

The table below lists standard material configuration for carbon steel and 316 stainless steel valves.*

	Carbon Steel	316 Stainless
<i>Body</i>	<i>Low-temp Carbon</i>	<i>316-SS</i>
<i>Guide</i>	<i>Low-temp Carbon</i>	<i>316-SS</i>
<i>Spring</i>	--- 316- or 302-SS ---	
<i>Poppet (incl. nut and cotter pin)</i>	--- 316-SS ---	

*Alternative materials available at additional cost

PRODUCT CERTIFICATIONS



Underwriters Laboratories, Inc.
Listed for propane, butane, and anhydrous ammonia



Canadian Registration Number
OC13500.5C

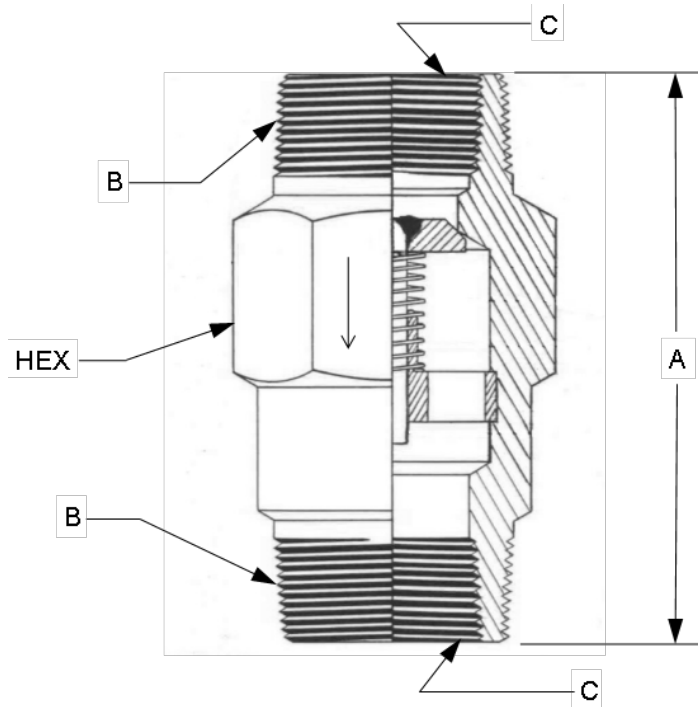

ORDERING INFORMATION				
Model	Dimensions (inches)			
	Number	A	B-MNPT	C-FNPT
143:FFDD	4.13	1 - 11 1/2	1/2-14	1.63
143:GGDD	4.13	1 1/4-11 1/2	1/2-14	1.88
143:GGEE	4.81	1 1/4-11 1/2	3/4-14	1.88
143:HHEE	4.81	1 1/2-11 1/2	3/4-14	2.13
143:HHFF	5.13	1 1/2-11 1/2	1-11 1/2	2.13
143:IIEE	5.31	2-11 1/2	3/4-14	2.75
143:IIFF	5.25	2-11 1/2	1-11 1/2	2.75
143:IIGG	5.63	2-11 1/2	1 1/4-11 1/2	2.75
143:JJFF	6.00	2 1/2-8	1-11 1/2	3.13
143:JJGG	6.31	2 1/2-8	1 1/4-11 1/2	3.13
143:JJHH	6.31	2 1/2-8	1 1/2-11 1/2	3.13
143:KKFF	6.50	3-8	1-11 1/2	4.00
143:KKGG	6.81	3-8	1 1/4-11 1/2	4.00
143:KKHH	6.56	3-8	1 1/2-11 1/2	4.00
143:KKII	6.56	3-8	2-11 1/2	4.00